

# **INSTRUCTION BULLETIN & MAINTENANCE MANUAL FOR CTD CS SERIES MODELS CS12**

**CTD MODEL NO:** \_\_\_\_\_

**CTD SERIAL NO:** \_\_\_\_\_

**MANUFACTURE DATE:** \_\_\_\_\_

**DISTRIBUTOR PURCHASED THROUGH:**

**(IF ANY)** \_\_\_\_\_



**CTD MACHINES**  
2382 East 48th Street  
Los Angeles, CA 90058  
Tel (213) 689-4455      FAX (213) 689-1255  
World Wide Web:

<b><u>TITLE</u></b>	<b><u>PAGE#</u></b>
Electrical Requirements.....	2
Introduction.....	3
Technical Information.....	3,4
Installation and Adjustments.....	4
Operation Instructions.....	5
Safety Information.....	6
Machine Maintenance.....	7
Issue Analysis.....	7
CS12 Electrical Schematic.....	8
How to Choose the Number of Teeth Needed on a Saw Blade.....	9
CS12 Parts Diagram.....	10
Material Cutting Speeds.....	11
Preventative Maintenance.....	12
Repair and Service.....	13

### **Electrical Requirements**

Based on one motor per machine

<u>Motor Size</u>	<u>Req. Amperage</u>	<u>Breaker Needed</u>	<u>Motor Size</u>	<u>Req. Amperage</u>	<u>Breaker Needed</u>
2 H.P 3Ph 208V	8 amp	20 amp	2 H.P 3Ph 460V	4 amp	20 amp
2 H.P 3Ph 230V	8 amp	20 amp	3 H.P 3Ph 460V	5 amp	20 amp

## Introduction

CS-12 cold saw are manual steel and tube cutting machines. They can cut multiple shapes, made from multiple materials, such as steel, stainless steels and aluminum. These machines are ideal for cutting all kinds of metal pipes. When cutting a material, make sure you follow all safety instructions. Some of these instructions include: always clamp down materials, slowly move the saw blade down to cut, return the saw blade to its original position after cutting a piece off.

These machine are easy to operate. They create low amounts of noise and have no dust pollution. A good cut should have no burr on either end of cut. This equipment can be used for high production. The location of the material being cut should not change position while it is being cut.

Machine dimensions: 47.25 inch x 39.37 inch x 70.85 inch

Machine weight: 617.25 lbs.

## Technical Information

### List 1

Name	Unit	CS12 Cold Saw
Motor	Amp	8 Amp
Voltage	V	208V/220V, 3 phase
Speed	low/med	50-175 ft. per min.
Cooling Pump Motor	V	208V/220V, 3 phase
Largest opening for clamps	In	5 inch
Suitable saw blade		High-speed steel saw blade 12/14
		Pin-hole 2mm x 11mm x 63mm
Weight	Lbs	617.25 lbs

## List 2

Max. Cutting Capacity		
	90°	45°
○	3.54 in	2.75 in
□	3.14 in x 3.14 in	2.75 in x 2.75 in
⊥	3.54 in x 3.54 in	2.75 in x 2.75 in
rectangle	3.93 in x 2.36 in	3.14 in x 1.96 in
●	1.77 in	1.37 in
■	1.77 in	1.37 in

## Installation and Adjustment

### (1). Machine Installation

Install the machine on leveled ground; bolt the machine to the floor. Use the four screw holes located at the bottom of the machine to bolt it down.

### (2). Electrical Installation

Connect the power cord to a 208V/220V, 3 Phase, 10 Amp power source. The machine will then be ready to use. To power the machines on, switch the power switch and emergency switch on. The blade will not activate until it is lowered for a cut. The blade will stay at the off position, even when turned on, while the base is at the resting position.

### (3). Pump and Flood System

The pump will activate when the blade is lowered for a cut. Make sure the lubrication tank is full before the unit is activated for the first time. Open the tank on the back of the machine to fill it, the only tool required to do so is a Philips screwdriver.

## **Operation Instructions**

- (1). Check the oil level on the gearbox.
- (2). Check the coolant/lubricant level on the tank.
- (3). Lock the material that will be cut by using the clamping mechanism.
- (4). Switch on the power switch and emergency button on the control box.
- (5). Set the correct blade speed on the gearbox. Harder materials should be cut at a lower speed. This machine has two speeds, low and medium.
- (6). Lower the machine head to the cutting location, the blade will begin to rotate, slowly and with force begin to cut the material. Fast cuts on thicker materials will create a low quality cut.
- (7). Return the machine head to the resting position once the material has been cut. The blade will stop moving once the head reaches the resting position.
- (8). Turn the power off on the machine.
- (9). Remove the material from the clamping mechanism.
- (10). Repeat these steps for every cut, with multiple cuts, you can start the process at step 3.

## **Safety Information**

- (1). Please wear safety glasses while operating this machine.
- (2). Check the blade guard for correct operation before use.
- (3). Do not wear any sleeves, or loose clothing while using this machine.
- (4). Follow all instructions and cut only the materials this machine was designed for.
- (5). Clamp all materials being cut as tightly as possible.
- (6). Check the blade regularly for sharpness. Do not cut any materials with a blunt blade.
- (7). Push the emergency button to stop the blade at any point or in case of an emergency.
- (8). Always power down the machine before walking away from it.
- (8). How to choose the rotating speed of the saw blade:

This machine comes set up with two cutting speeds, slow and medium. Use the toggle switch on the control box to choose the correct blade speed before you cut. Harder materials should always be cut at a lower speed.

## Machine Maintenance

- (1). Check the oil level for the gearbox regularly. A glass window is located on the right side of the machine, it will show the current oil level.
- (2). Oil in the gearbox should be drained and changed every six months of extended use.
- (3). Clean the clamping mechanism and add grease on a weekly basis
- (4). Clean the saw blade regularly with clean a cloth. Removing metal residue from it, will increase the life of the blade.
- (5). Worm gears and bearing should be changed every 3 to 5 years of extended use.

## 7. Issue Analysis

No.	Fault	Fault Analysis
1	Power will not turn on	Machine is not receiving any a. power from the source. Power breakers are off, reset and set to the on b. position
2	After finishing a cut, the blade will not stop.	a. Rear proximity switch is not being activated or is damaged.
3	The blade will not turn, when the machine head is on the cutting position	a. Rear proximity switch is stuck on the off off position or is damaged.
4	Pump is not running	Check the wiring on the pump, check pump for a. any type of damage.

## CS12 Electrical Schematic

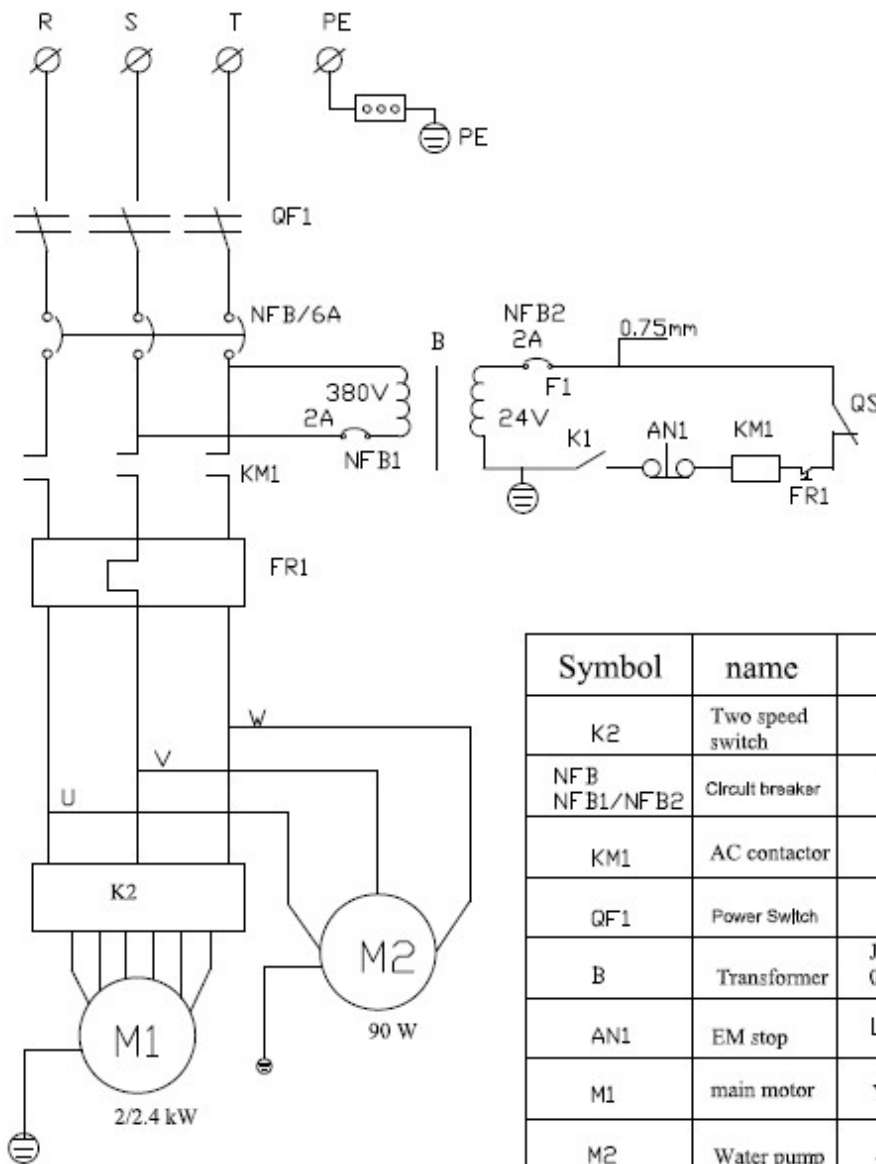

Symbol	name	model
K2	Two speed switch	LW42A2
NFB NFB1/NFB2	Circuit breaker	C4 6A 2A/2A
KM1	AC contactor	S-P21
QF1	Power Switch	LW42B2
B	Transformer	JBK3-63VA 0-220-415/0-24-36-24V
AN1	EM stop	LA39
M1	main motor	YD100L-4/2
M2	Water pump	Y80M12
K1	Handle Switch	TM-25
FR1	Thermal relay	TH-P20E
QS	Journey Switch	TZ-7310



## How to choose the number of teeth needed on a blade

thickness	¢ 10"	¢ 12"	¢ 14"
0.023	280T	320T	350T
0.031	280T	320T	320T
0.039	240T	280T	320T
0.047	220T	240T	280T
0.055	200T	220T	240T
0.062	200T	220T	240T
0.078	180T	200T	220T
0.098	180T	200T	220T
0.11	150T	180T	200T
Solid ¢ .75	120T	128T	150T
Solid ¢ .86	120T	128T	150T
Solid ¢ 1	90T	110T	128T
Solid ¢ 1.25	90T	100T	120T
Solid ¢ 1.5	64T	80T	100T

# CS12 Parts Diagram

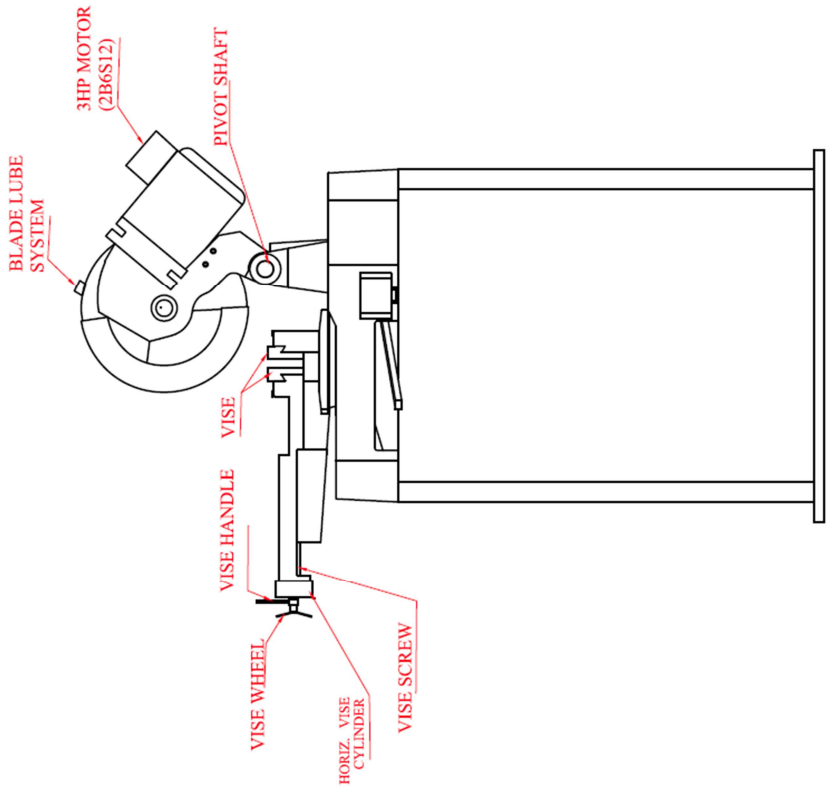
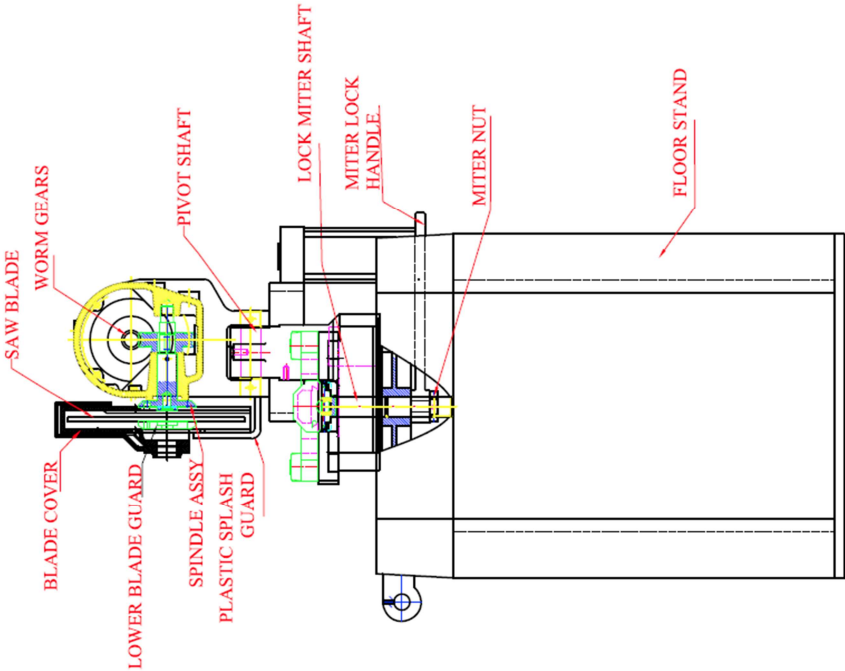

## Material Cutting Speeds

<u>Cutting speeds for various materials using a plain high speed steel cutter</u>		
<u>Material type</u>	<u>Meters per min (MPM)</u>	<u>Surface feet per min (SFM)</u>
<u>Steel (tough)</u>	<u>15–18</u>	<u>50–60</u>
<u>Mild Steel</u>	<u>30–38</u>	<u>100–125</u>
<u>Cast Iron (medium)</u>	<u>18–24</u>	<u>60–80</u>
<u>Alloy Steels (1320–9262)</u>	<u>20–37</u>	<u>65–120</u>
<u>Carbon Steels (C1008–C1095)</u>	<u>21–40</u>	<u>70–130</u>
<u>Free Cutting Steels (B1111–B1113 &amp; C1108–C1213)</u>	<u>35–69</u>	<u>115–225</u>
<u>Stainless Steels (300 &amp; 400 series)</u>	<u>23–40</u>	<u>75–130</u>
<u>Bronzes</u>	<u>24–45</u>	<u>80–150</u>
<u>Leaded Steel (Leadloy 12L14)</u>	<u>91</u>	<u>300</u>
<u>Aluminium</u>	<u>75–105</u>	<u>250–350</u>
<u>Aluminum (with coolant)</u>	<u>150-210</u>	<u>500-700</u>
<u>Brass</u>	<u>90–210</u>	<u>300–700</u>

## **Preventative Maintenance:**

The CS Series machines are relatively easy machines to operate and maintain.

Following is a weekly check list of General Maintenance items. The best preventative maintenance advice is to *CLEAN THE MACHINE DAILY*, especially around the pivot points on the machine.

## **Lubrication and Adjustments of Bearings:**

**NO LUBRICATION OR ADJUSTMENTS ARE REQUIRED.** All CTD cold saws are assembled using sealed, prelubricated ball bearings. The springs eliminate the need for adjustments of bearings and also greatly increase the life of the bearings. All air cylinders are “lube for life”.

## **General Maintenance Weekly Check List:**

Always disconnect electrical power and air supply.

1. Keep machine clean—especially around pivot bracket and pivot bearings.
2. Blow off and clean around the cylinder
3. Check Air Filter Bowl for water and condensation build up.
4. Remove any scrap pieces and dust build up from inside floor stand (if purchased).
5. Check monthly;
  - A. For excessive belt wear
  - B. Make sure motor pulley set screws are tight.

## **Repair and Service:**

Always use CTD factory authorized replacement parts and consult factory before making any repairs or adjustments which may be unclear.

### **Motor Warranty:**

Motors which fail during the warranty period of one (1) year must be returned to an authorized Baldor Service Representative for examination to determine whether the failure was caused by manufacturing. In the event a replacement is required before factory examination, a motor will be sold at the list price. If the factory authorizes replacement, CTD will credit customer's account for the replacement cost. All motors are shipped F.O.B. CTD, Los Angeles, CA Plant.

### **Guarantee:**

CTD warrants that their cut-off machines and accessories are free from defect of material, workmanship, and title, and are of the kind of quality indicated and described in applicable specifications. The foregoing warranty is exclusive and in lieu of all other warranties, whether written or oral. CTD's obligation under the foregoing warranty is limited to the repair or replacement (at CTD's option) of the part which is defective in materials or workmanship for a period of one (1) year from the date of shipment to the original purchaser, whether for warranties, negligence, or otherwise, shall not in any way include consequential damages, or costs of removing or re-installing the products. All parts and machines are shipped F.O.B. CTD, Los Angeles, CA Plant.



## **CTD MACHINES**

**2382 E. 48th Street      Los Angeles, CA 90058**

**Tel (213) 689-4455      FAX (213) 689-1255**

World Wide Web:

e-mail: [ctdsaw@ctdsaw.com](mailto:ctdsaw@ctdsaw.com)